

LED Lighting Fixtures EXFL-LE Series FL LED & Emergency Type

❖ Description

EXFL-LE Series Fluorescent & LED lighting fixtures are used :

- In heavy process industries having environments where flammable or explosive vapors or gases are present.
- In hazardous areas, both indoors and outdoors where long life and low maintenance costs are desired.
- In petroleum, chemical, petrochemical and other heavy process industry facilities.
- Where ignitable concentrations of flammable gases, vapors or liquids can exist all of the time or some of the time under normal operation conditions.
- In installations where moisture, dirt, dust, vibration, corrosion and rough usage are problems.

❖ Features

- The flameproof enclosures of lamp (FL, LED) and FL ballast, LED SMPS are separated from each other with barrier walls and sealing glands.
- The lamp housing has a tubular lamp cover cemented into the lamp holder casings at the both ends. One casing contains a fixed lamp holder and the other a relamping lamp holder.

❖ Certification

- EX db IIC T6 IP66
- Ex tb IIIC T80°C Db IP66
- INERIS 12ATEX0020X

❖ Standard Finish

- MUNSELL No. 7.5BG 6/1.5
- If you want another color, contact us please.

❖ Dimension

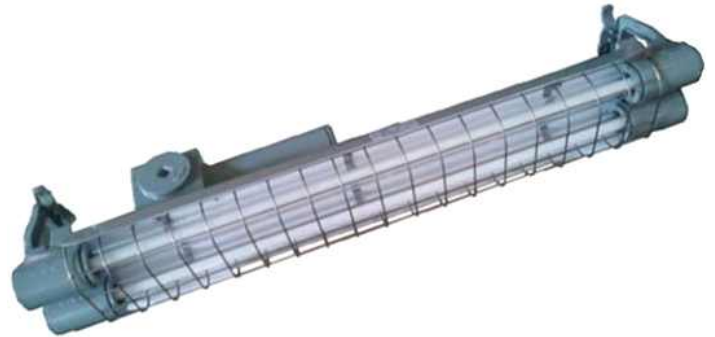
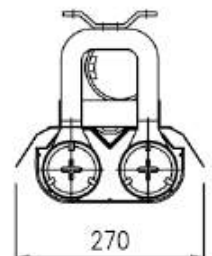
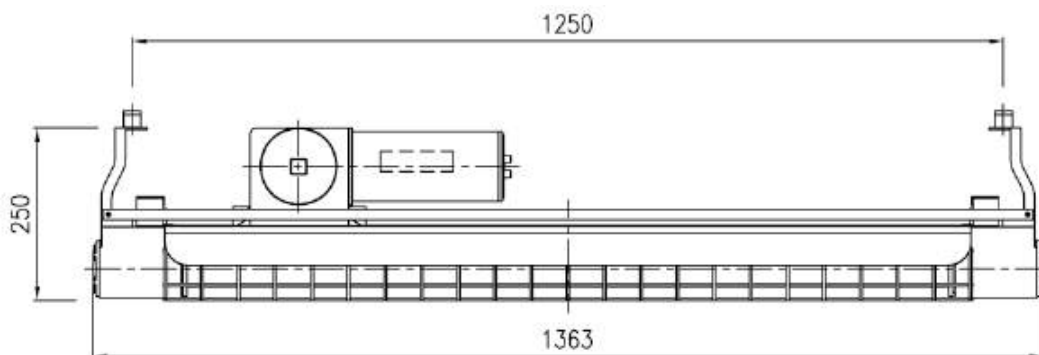

❖ Standard Materials

- Enclosure : Cast aluminium alloy
- Protection Tube : Heat resistant hard tubing glass
- Guard : Stainless Steel
- Reflector : Sheet Steel (Stove enamelled white inside)
- Ballast Mounting Box : Cast aluminium alloy

❖ Technical Data

Rated Wattage	LED 14W/ 17W/ 18W x1 or x2
Rated Voltage	AC 220V / 230V / 240V / 250V
Rated Frequency	50Hz / 60Hz
Entry Size	1/2", 3/4", M20, M25

Emergency

Battery Rating	Operating Time
16.8V 2.0Ah (Ni-Cd)	1.0hr over