

## LED Lighting Fixture ELE/U Series with High Efficiency LED

### \* Application

- Complies with IEC 60079-0, 1 and 31.
- Hazardous locations due to the presence of flammable gases or vapors, water and moisture.
- Petroleum refineries, chemical and petrochemical plant with indoor and outdoor processes.

### \* Features

- Internal SMPS type
- Luminous efficiency : 150 lm/w (standard)  
180 lm/w (option)
- Color temperature : 5700K ± 355 (standard)  
2700K ~ 6000K (option)
- Color rendering index : 80 over
- Beam angle : 120°
- Ambient temperature : -20°C to 50/55°C

### \* Certification

- Ex db IIC T5/T6 Gb IP66
- Ex tb IIIC T85°C/T80°C Db IP66
- IECEx KTL 23.0010X

### \* Standard Materials

- Enclosure: Aluminium Die-casting
- Globe: Tempered glass

### \* Standard Finish

- MUNSELL No. 7.5BG 6/1.5
- If you want another color, contact us please.

### \* Photometric Data

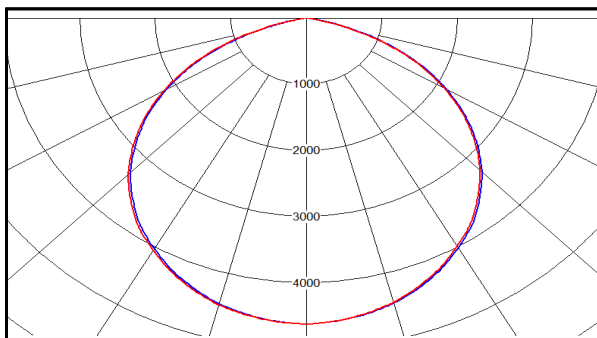

<80W>



### \* Technical Data

Rated voltage	Max. 240V, 50/60 Hz			
Rated power	30W	45W	60W	80W
Rated ampere	0.15A	0.23A	0.3A	0.4A
Luminous flux	4500lm	6750lm	9000lm	12000lm

### \* Cable Entry

Entry Standard	Metric	M20	M25	M32	Mounting Type
	NPT/PF	1/2"	3/4"	1"	
Entry Location/ Q'ty	Mounting Box	4	4	4	Ceiling, Bracket, Pendant
	Junction Box	2	2	2	Hand Rail, Stanchion

## \* Dimension

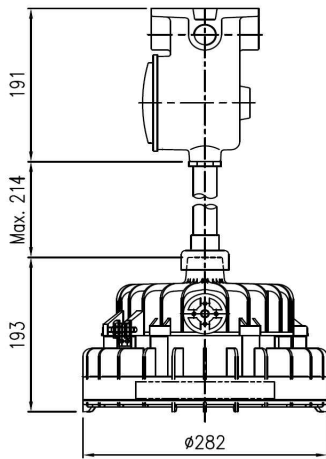

PENDANT TYPE

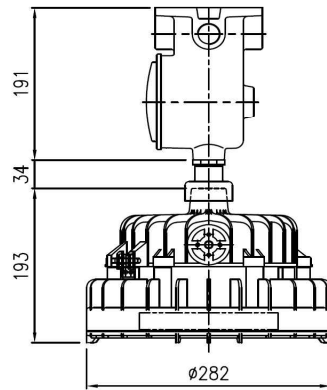

CEILING TYPE

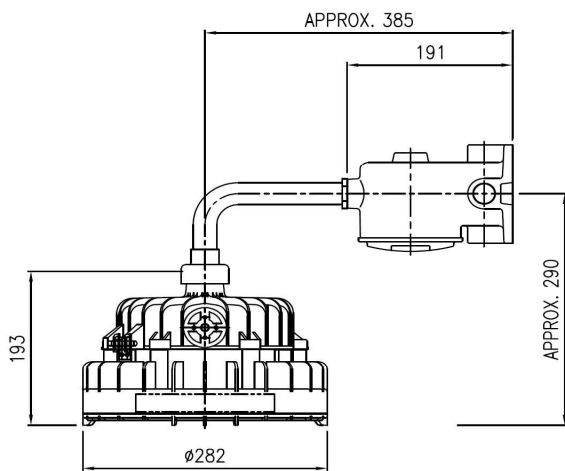
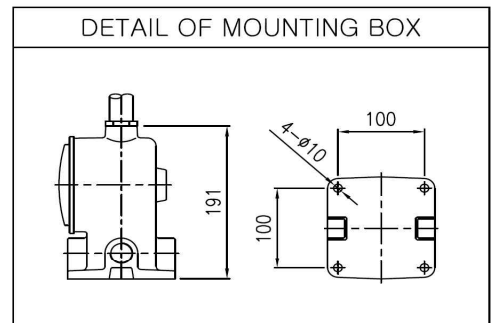

90° BRACKET TYPE

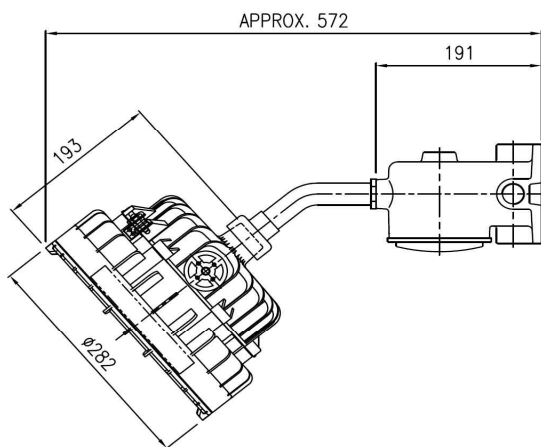

40 BRACKET TYPE

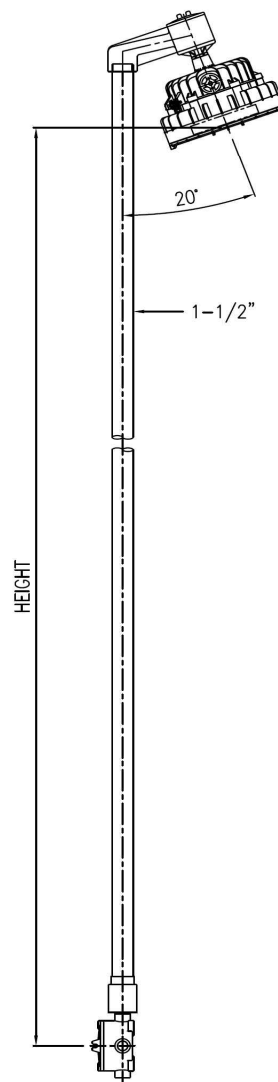

HANDRAIL

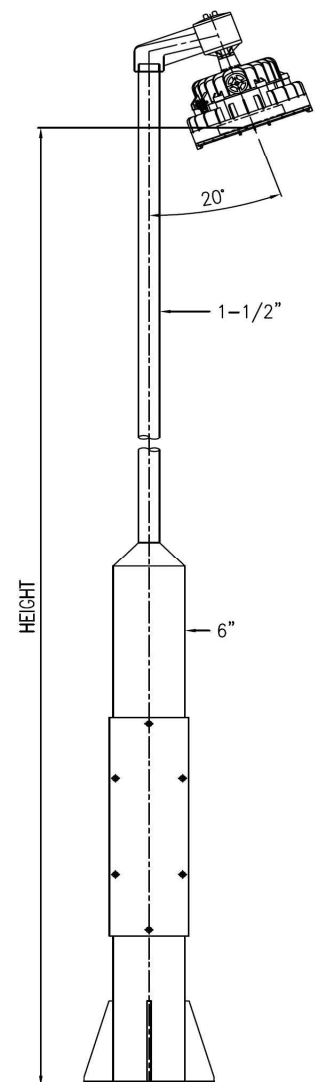

STANCHION